

Rad-hard adjustable negative voltage regulator

Datasheet - production data

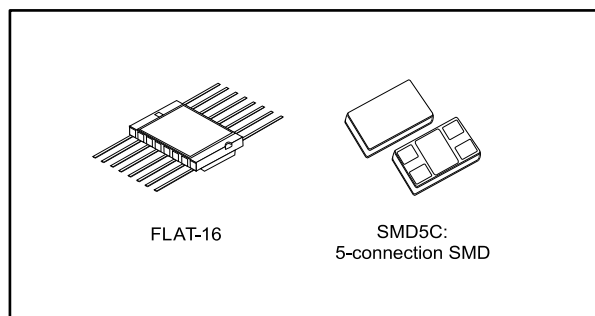

Features

- 3 A low dropout voltage
- Optional overtemperature and overcurrent protection
- Adjustable overcurrent limitation
- Load short circuit monitoring
- Adjustable output voltage
- Inhibit (ON/OFF) TTL-compatible control
- Programmable output short-circuit current limitation
- Remote sensing operation
- Rad-hard: sustains 300 krad in Mil-1019.7 at High & ELDRS low dose rate conditions
- Heavy ions, SEL immune at 68 MeV/cm²/mg LET ions

Description

The RHFL7913A adjustable is a high performance Rad hard negative voltage regulator. Available in FLAT-16 and new SMD5C hermetic ceramic packages, it is specifically intended for space and harsh radiation environments. It provides exceptional electrical performances, high speed and low dropout voltage. Input supply ranges from - 3 V to - 12 V. It also provide logical control / monitor functions (inhibit, output monitor, short-circuit control) from/to external positive voltage signals, while the entire RHFL7913A adjustable analog functions are biased at negative voltages with respect of ground pin. The device is QML-V qualified with SMD 5962-02532.

Contents

1 Diagram..... 5

2 Pin configuration 6

3 Maximum ratings 7

4 Electrical characteristics 8

5 Device description..... 10

 5.1 ADJ pin 10

 5.2 Inhibit ON-OFF control 10

 5.3 Overtemperature protection 10

 5.4 Overcurrent protection 10

 5.5 OCM pin 10

 5.6 Alternates to 10

6 Application information 11

 6.1 Remote sensing operation 12

7 Die information 13

8 Package information 14

 8.1 FLAT-16 package information 14

 8.3 SMD5C package information 16

 8.5 Packing information..... 17

9 Order code 18

10 Revision history 19

List of tables

Table 1: Pin description	6
Table 2: Maximum operating ratings	7
Table 3: Thermal data.....	7
Table 4: Recommended operating conditions	7
Table 5: Electrical characteristics	8
Table 6: Flat-16 (MIL-STD-1835) mechanical data	15
Table 7: SMD5C mechanical data	16
Table 8: Order code	18
Table 9: Part number - SMD equivalent	18
Table 10: Environmental characteristics.....	18
Table 11: Document revision history	19

List of figures

Figure 1: Block diagram	5
Figure 2: Pin configuration (top view for FLAT-16, bottom view for SMD5C).....	6
Figure 3: DIE size	13
Figure 4: Flat-16(MIL-STD-1835) package outline	14
Figure 5: SMD5C package outline.....	16

1 Diagram

Figure 1: Block diagram

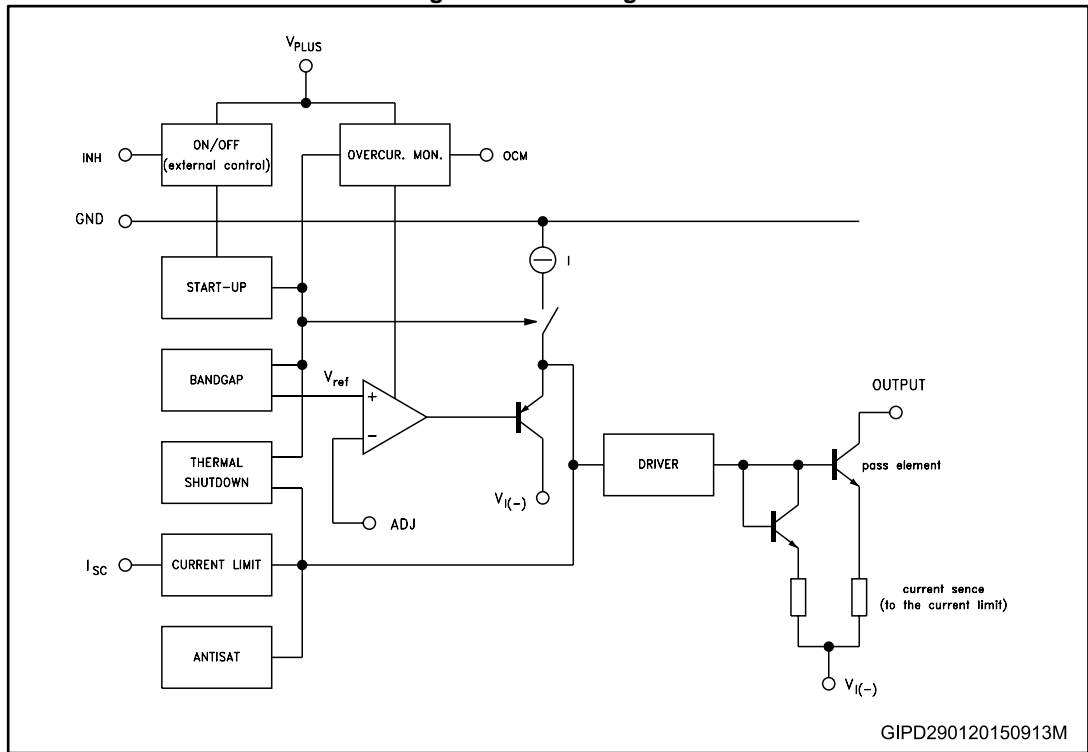

2 Pin configuration

Figure 2: Pin configuration (top view for FLAT-16, bottom view for SMD5C)

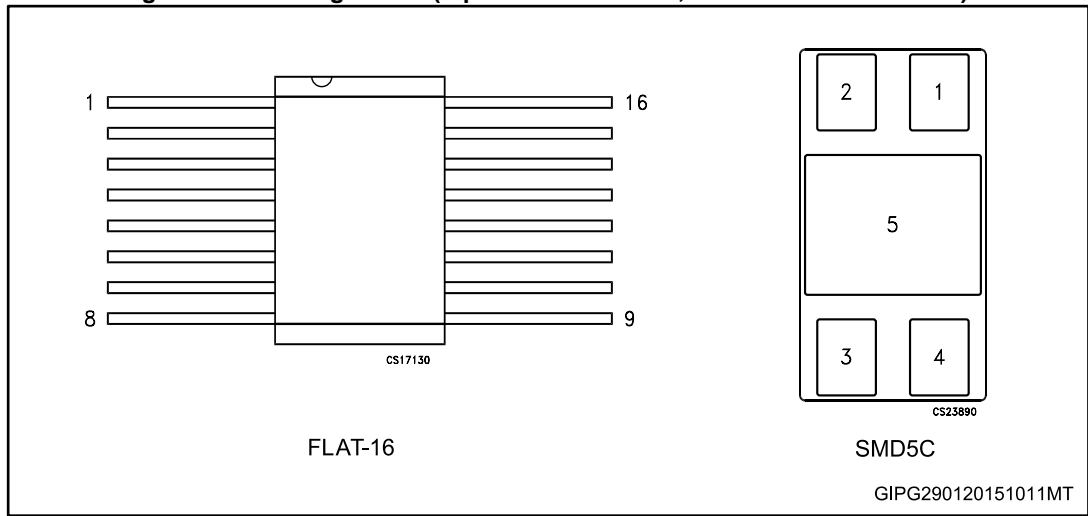

Table 1: Pin description

Pin n°	FLAT-16 ⁽¹⁾	SMD5C ⁽²⁾
DSCC part ident.	5962-02532	5962-02532
1	V _I , negative input	V _O , negative output
2	V _I , negative input	ADJ
3	V _I , negative input	Inhibit
4	I _{sc}	GND
5	OCM	V _I , negative input
6	V _{PLUS} , positive supply	
7	GND	
8	N.C.	
9	N.C.	
10	GND	
11	Inhibit	
12	ADJ	
13	N.C.	
14	V _O , negative output	
15	V _O , negative output	
16	V _O , negative output	

Notes:

⁽¹⁾The upper metallic package lid and the bottom metallization are neither connected to regulator die nor to package terminals, hence electrically floating.

⁽²⁾The upper metallic package lid is neither connected to regulator die nor to package terminals, hence electrically floating.

3 Maximum ratings

Table 2: Maximum operating ratings

Symbol	Parameter		Value	Unit
V_I	DC input voltage $ V_{IN} - V_{PLUS} $		-12	V
V_{PLUS}	Logical block supply voltage $V(+)$ - $V(GND)$, unless grounded		+5	
V_I	DC voltage, $V_{IN} - GND$, $V_{PLUS} = 0$ V		-12	
V_I	DC voltage, $V_{IN} - GND$, $V_{PLUS} = +3$ V		-9	
V_O	DC output voltage range		-9 to -1.20	
I_{OUT}	Output current	RHFL7913KPA	2	A
		RHFL7913SCA	3	
P_D	TC = 25 °C power dissipation	RHFL7913KPA	15	W
		RHFL7913SCA	15	
T_{STG}	Storage temperature range		-65 to + 150	°C
T_{OP}	Operating junction temperature range		-55 to + 150	
ESD	Electrostatic discharge capability		Class 3	



Absolute maximum ratings are those values beyond which damage to the device may occur. Functional operation under these conditions is not implied.

Table 3: Thermal data

Symbol	Parameter	Value	Unit
R_{thJC}	Thermal resistance junction-case, FLAT-16 and SMD5C	8.3	°C/W
T_{SOLD}	Maximum soldering temperature, 10 sec.	300	°C

Table 4: Recommended operating conditions

Symbol	Parameter		Value	Unit
V_I	Input voltage range V_I (at $V_{PLUS} = 0$ V)		-12 to -1.3	V
V_{PLUS}	Positive supply range		0 to +3	V
V_O	Output voltage range	$V_{PLUS} = 0$ V, $V_I = -12$ to -3.7 V	-9.5 to -1.2	V
		$V_{PLUS} = +3$ V, $V_I = -9$ to -3.7 V	-6.5 to -1.2	V
T_A	Ambient operating temperature range		-55 to +125	°C

4 Electrical characteristics

$T_J = 25\text{ }^\circ\text{C}$, $V_I = V_O + 2.5\text{ V}$, $C_I = C_O = 1\text{ }\mu\text{F}$, unless otherwise specified.

Table 5: Electrical characteristics

Symbol	Parameter	Test conditions	Min.	Typ.	Max.	Unit
V_I	Operating input voltage	$I_O = 1\text{ A (KPA) or } 2\text{ A (SCA)}$	-12			V
V_O	Operating output voltage	$I_O = 1\text{ A}, V_O = -1.2\text{ V, FLAT } 16$	-1.28		-1.16	V
		$I_O = 1\text{ A}, V_O = -9\text{ V, FLAT } 16$	-9.6		-8.7	
		$I_O = 2\text{ A}, V_O = -1.2\text{ V, SMD5C}$	-1.28		-1.16	
		$I_O = 2\text{ A}, V_O = -9\text{ V, SMD5C}$	-9.6		-8.7	
$\Delta V_O/\Delta V_I$	Line regulation	$V_I = V_O - 2.5\text{ V to } -12\text{ V}, I_O = 5\text{ mA}$ $T_J = 25\text{ }^\circ\text{C}$			0.2	%
		$V_I = V_O - 2.5\text{ V to } -12\text{ V}, I_O = 5\text{ mA}$ $T_J = -55\text{ }^\circ\text{C and } +125\text{ }^\circ\text{C}$			0.5	
$\Delta V_O/V_O$	Load regulation	$V_I = V_O - 2.5\text{ V}, I_O = 5\text{ mA to } 400\text{ mA}$ $T_J = 25\text{ }^\circ\text{C}$			0.4	
		$V_I = V_O - 2.5\text{ V}, I_O = 5\text{ mA to } 400\text{ mA}$ $T_J = -55\text{ }^\circ\text{C and } +125\text{ }^\circ\text{C}$			0.5	
		$V_I = V_O - 2.5\text{ V}, I_O = -5\text{ mA to } 1\text{ A},$ $T_J = 25\text{ }^\circ\text{C}$			0.5	
		$V_I = V_O - 2.5\text{ V}, I_O = 5\text{ mA to } 1\text{ A}$ $T_J = -55\text{ }^\circ\text{C and } +125\text{ }^\circ\text{C}$			0.6	
I_Q	Quiescent current ON MODE	$I_O = 5\text{ mA}, V_I = V_O - 2.5\text{ V}, T_J = 25\text{ }^\circ\text{C}$	-3			mA
		$I_O = -30\text{ mA}, V_I = V_O - 2.5\text{ V},$ $T_J = 25\text{ }^\circ\text{C}$	-6			
		$I_O = 300\text{ mA } V_I = V_O - 2.5\text{ V}$ $T_J = 25\text{ }^\circ\text{C and } +125\text{ }^\circ\text{C}$	-15			
		$I_O = 300\text{ mA } V_I = V_O - 2.5\text{ V},$ $T_J = -55\text{ }^\circ\text{C}$	-20			
		$I_O = 1\text{ A } V_I = V_O - 2.5\text{ V}$ $T_J = 25\text{ }^\circ\text{C and } +125\text{ }^\circ\text{C}$	-30			
		$I_O = 1\text{ A } V_I = V_O - 2.5\text{ V}, T_J = -55\text{ }^\circ\text{C}$	-50			
		$I_O = 3\text{ A } V_I = V_O - 2.5\text{ V}, V_{INH} = 0$ $T_J = +25\text{ }^\circ\text{C and } +125\text{ }^\circ\text{C}$ Only for SMD5C	-90			
		$I_O = 2\text{ A } V_I = V_O - 2.5\text{ V}, V_{INH} = 0$ $T_J = -55\text{ }^\circ\text{C}$ Only for SMD5C,	TBD			
I_Q	Quiescent current OFF MODE	$V_O = -1.2\text{ V}, V_I = -7\text{ V}, V_{PLUS} = +5\text{ V}$ $V_{INH} > 2.3\text{ V}, T_J = -55\text{ }^\circ\text{C to } +125\text{ }^\circ\text{C}$			1	mA
V_D	Dropout voltage	$I_O = 400\text{ mA } V_O = -2.5\text{ V to } -9\text{ V}$ $T_J = 25\text{ }^\circ\text{C}$	-450			mV

Symbol	Parameter	Test conditions	Min.	Typ.	Max.	Unit
		$I_O = 400 \text{ mA}$ $V_O = -2.5 \text{ V to } -9 \text{ V}$ $T_J = -55^\circ\text{C and } +125^\circ\text{C}$	-500			
		$I_O = 1 \text{ A}$ $V_O = -2.5 \text{ V to } -9 \text{ V}$ $T_J = 25^\circ\text{C}$	-750			
		$I_O = 1 \text{ A}$ $V_O = -2.5 \text{ V to } -9 \text{ V}$ $T_J = -55^\circ\text{C and } +125^\circ\text{C}$	-800			
$I_{PLUS}^{(1)}$	V_{PLUS} current	$V_I = -5.5 \text{ V}$, $V_{PLUS} = 5 \text{ V}$, $V_{INH} = 5 \text{ V}$ $T_J = 25^\circ\text{C}$			0.75	mA
		$V_I = -5.5 \text{ V}$, $V_{PLUS} = +5 \text{ V}$, $V_{INH} = 5 \text{ V}$ $T_J = -55^\circ\text{C and } +125^\circ\text{C}$			1	
$SVR^{(1)}$	Supply voltage rejection	$V_I = V_O - 2.5 \text{ V}$, $I_O = 5 \text{ mA}$, $F = 120 \text{ Hz}$	60			dB
		$V_I = V_O - 2.5 \text{ V}$, $I_O = 5 \text{ mA}$, $F = 33 \text{ kHz}$	20			
$t_{PLH}^{(1)}$	Inhibit propagation delay	$V_{INH} < 0.8 \text{ V}$, $V_{PLUS} = 5 \text{ V}$ $V_I = V_O - 2.5 \text{ V}$ $I_O = 400 \text{ mA}$			20	μs
$t_{PHL}^{(1)}$	Inhibit propagation delay	$V_{INH} > 2.3 \text{ V}$, $V_{PLUS} = 5 \text{ V}$ $V_I = V_O - 2.5 \text{ V}$ $I_O = 400 \text{ mA}$			100	
$V_{INH(ON)}$	Inhibit voltage	$V_I = -7 \text{ V}$ $V_{PLUS} = +5 \text{ V}$ $I_O = 5 \text{ mA}$ $T_J = -55^\circ\text{C to } 125^\circ\text{C}$			0.8	V
$V_{INH(OFF)}$			2.3			
I_{SH}	Shutdown input current	$V_{INH} = 5 \text{ V}$		15		μA
V_{OCM}	OCM pin voltage	Sinked $I_{OCM} = 10 \text{ mA}$, active low		0.38		V
en	Output noise voltage	$f = 10 \text{ Hz to } 100 \text{ kHz}$ $I_O = 5 \text{ mA to } 2 \text{ A}$		40		μVrms

Notes:

⁽¹⁾These values are guaranteed by design. For each application it's strongly recommended to comply with the maximum current limit of the package used.

5 Device description

The RHFL7913A adjustable contains a NPN-type power element controlled by signal resulting from amplified comparison between internal temperature compensated band-gap cell and the fraction of the desired output voltage value, generated by an external resistor divider bridge. The NPN structure allows access to lower drop out levels because its base current can be routed to ground pin and not to output. To control and monitor the device from / to the external logic world – usually operating in positive voltage area – a dedicated logic interface block (INHIBIT and OCM functions) has been implemented with +3 V to +5 V supplied line V(+). In case V(+) = 0 V, inhibit and OCM functions are not available: In this condition, INHIBIT function is ON and OCM pin is “no care”. The device is internally protected by several blocks.

5.1 ADJ pin

The load voltage feedback comes from an external divider resistor bridge middle point to ADJ pin established between load terminals.

5.2 Inhibit ON-OFF control

When INHIBIT pin is TTL-high (positive), the device switches off current and voltage output. The device is ON when INHIBIT pin is set TTL-low.

5.3 Overtemperature protection

A temperature detector internally monitors power element junction temperature. The device goes OFF ~165° - 175°C are reached, and returns ON when circa 100°C. When internal temperature detector reaches 170°C, the active power element can be at 225 °C: Device reliability cannot be granted during extensive operation duration with these conditions.

5.4 Overcurrent protection

I_{SC} pin. An internal non-fold back short-circuit limitation is set with I_{SHORT} > 4 A (V_O is 0 V). This value can be downward modified by an external resistor connected between I_{SC} and V_I pins, with a typical value range of 10 kΩ to 200 kΩ. To keep excellent V_O regulation, it is necessary to set I_{SHORT} 1.6 times greater than the maximum desired application I_O. When I_O reaches I_{SHORT} – 300 mA, the current limiter overrules regulation and V_O starts to drop and OCM flag is risen. When no current limitation adjustment is required, I_{SC} pin shall be left unbiased (as it is in 3 pin packages).

5.5 OCM pin

Goes low when current limiter starts to be active, otherwise V_{OCM} = V (+). It is bufferized and can sink 10 mA. OCM pin is internally pulled-up by a 50 kΩ resistor. Can be left open when V (+) = 0.

5.6 Alternates to

RHFL7913A is recommended to replace all industry negative regulators due to its exceptional radiation performances. To replace 3-terminal industry devices, use customized RHFL7913 fixed voltage versions.

6 Application information

Adjusting output voltage: R1 resistor must be connected between V_O and ADJ pins. R2 resistor must be connected between ADJ and GND pins. Resistor values can be derived from the following formula:

$$V_O = V_{ADJ} (1 + R1/R2) \text{ with } V_{ADJ} = -1.20 \text{ V}$$

To access all RHFL7913A adjustable functionality, V (+) shall be set at 3.0 V (max 5 V). As a consequence, V_I (-) cannot be greater than -9.0 V (resp. -7 V) due to -12 V maximum operation rating.

The device is functional as soon as $V_I - V_O$ voltage difference is slightly above power element saturation voltage. The adjustable pin to Ground resistor shall not be greater than 10 k Ω to make output feedback error be below 0.2%. A minimum 0.5 mA I_O is necessary to set to ensure perfect "no-load" regulation. It can be wise to dissipate this current into the divider bridge resistor.

All available V_I pins shall always be PCB interconnected, the same for all available V_O pins, otherwise device stability and reliability cannot be granted. The INHIBIT function switches off output current in an electronic way, is very quickly. According to Lenz' Law, external circuitry reacts with $-Ldi/dt$ terms which can be of high amplitude in case some series-inductance exists. Effect would be large transient voltage developed on both device terminals. External Schottky diodes set on V_I and V_O may prevent voltage excursions beyond max ratings. In the worst case, a 14 V Zener diode shall protect the device input. In case of capacitive load, a input-output protection diode can be necessary to prevent V_O to be greater than V_I during transient operation.

The device has been designed for high stability and low drop out operation: minimum 1 μ F input and output tantalum capacitors are therefore mandatory. Typical industry PCB design practices 10 μ F capacitors values are acceptable. Capacitor ESR range is from 0.020 Ω to over 20 Ω . Such range turns out to be useful when ESR increases at low temperature. When large transient currents are expected, larger value capacitors are necessary.

In case of high current operation with expected short-circuit events, caution shall be considered relatively to capacitors. They shall be connected as close as possible from device terminals. As some tantalum capacitors may permanently fail when submitted to high charge-up surge currents, it is recommended to decouple them with 470 nF polyester or ceramic capacitors.

RHFL7913A adjustable being manufactured with very high speed bipolar technology (6 GHz f_T transistors), the PCB layout shall be performed with unprecedented care, very low inductance, low mutually coupling lines, otherwise high frequency parasitic signals may be picked-up by the Device resulting into system self-oscillation. In difficult high current circumstances (coming from PCB layout) a 470 nF polyester capacitor connected between V_O and ADJ pin increases stability margins. Benefit is SVR performances extended to far higher frequencies.

6.1 Remote sensing operation

When load is physically far away from device output, the adjustable line can be set as a kelvin sense line by implementing the divider resistor bridge as close as possible from device, with a decoupling capacitor. The adjust pin kelvin sense line (to be not coupled with power line) picks-up load voltage (load also locally decoupled with a capacitor). This layout eliminates ohmic drop in load power wire. Similarly, by taking advantage of two separate ground terminals: power ground pin shall be directly connected to load ground terminal which is also the system ground, device signal ground shall be separately connected to load ground terminal by another kelvin line: In this way, ground ohmic errors are minimized because the only current flowing into device signal ground pin kelvin line is device I_q (a matter of a few mA).

7 Die information

RHFL7913A adjustable is also available in die form. Space dice are electrically tested by STMicroelectronics in such a way that, when mounted in proper thermal and electrical substrate, they are in full compliance with equivalent packaged device:

DIE physical dimensions.

DIE size: 110 mils x 166 mils

DIE thickness: 375 μm +/-25 μm (14.8 mils +/- 1 mil)

Pad size:

V_I , V_O pads: 245 μm x 544 μm

Control pads: 184 μm x 184 μm

Interface materials

Top Metallization: Al/Si/Cu 1.05 μm +/- 0.15 μm

Backside metallization: None

Glassivation

Type: P.Vapox + Nitride

Thickness: 0.6 μm +/- 0.1 μm + 0.6 μm +/-0.08 μm

Substrate: Silicon (connected to $V_I = V_{\text{minus}}$)

The SENSE pad is layout on the die but is not electrically connected to the IC and shall be left non-bonded during hybrid bonding.

Figure 3: DIE size

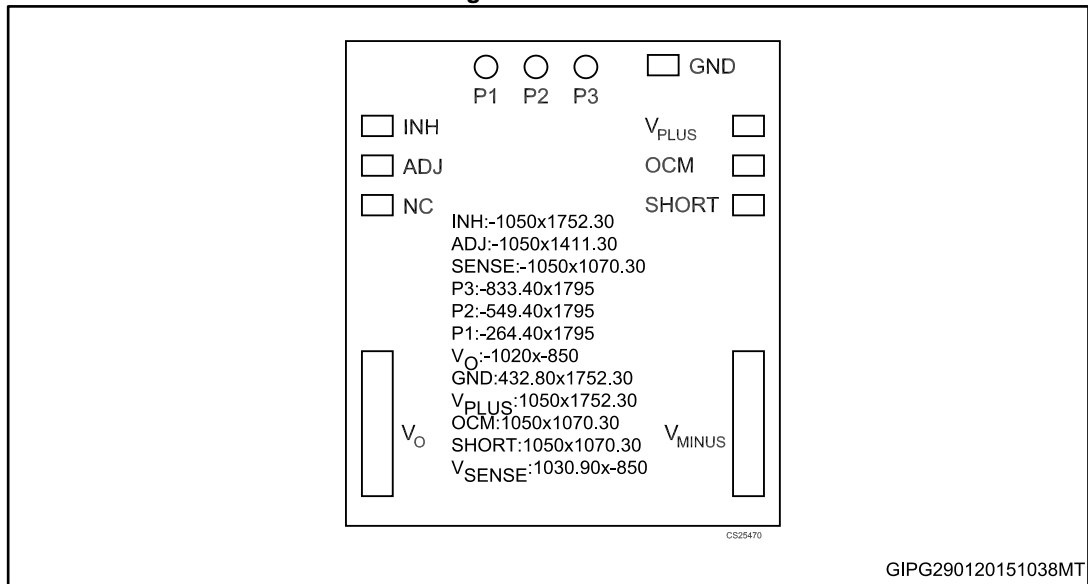

8 Package information

In order to meet environmental requirements, ST offers these devices in different grades of ECOPACK[®] packages, depending on their level of environmental compliance. ECOPACK[®] specifications, grade definitions and product status are available at: www.st.com. ECOPACK[®] is an ST trademark.

8.1 FLAT-16 package information

Figure 4: Flat-16(MIL-STD-1835) package outline

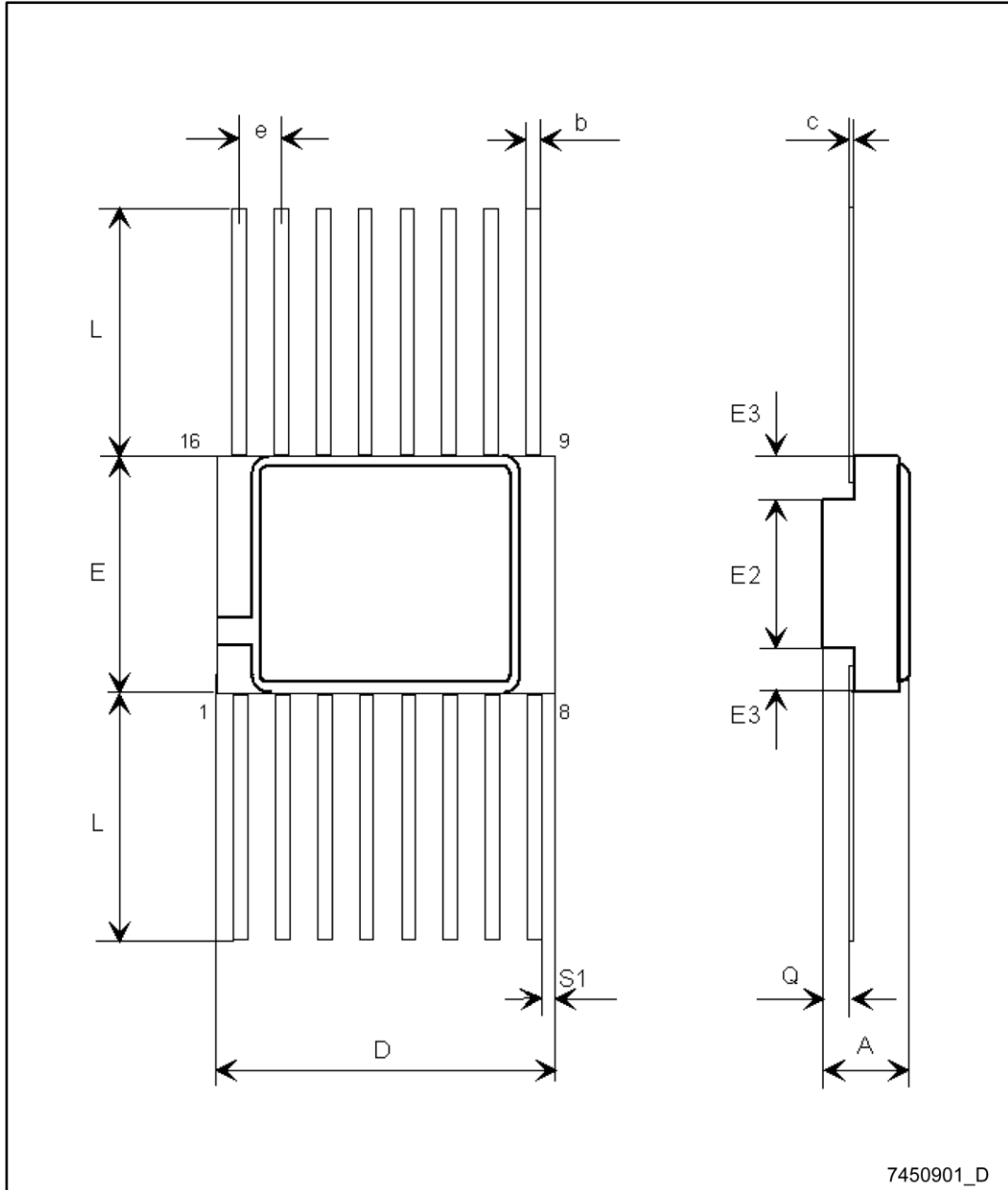
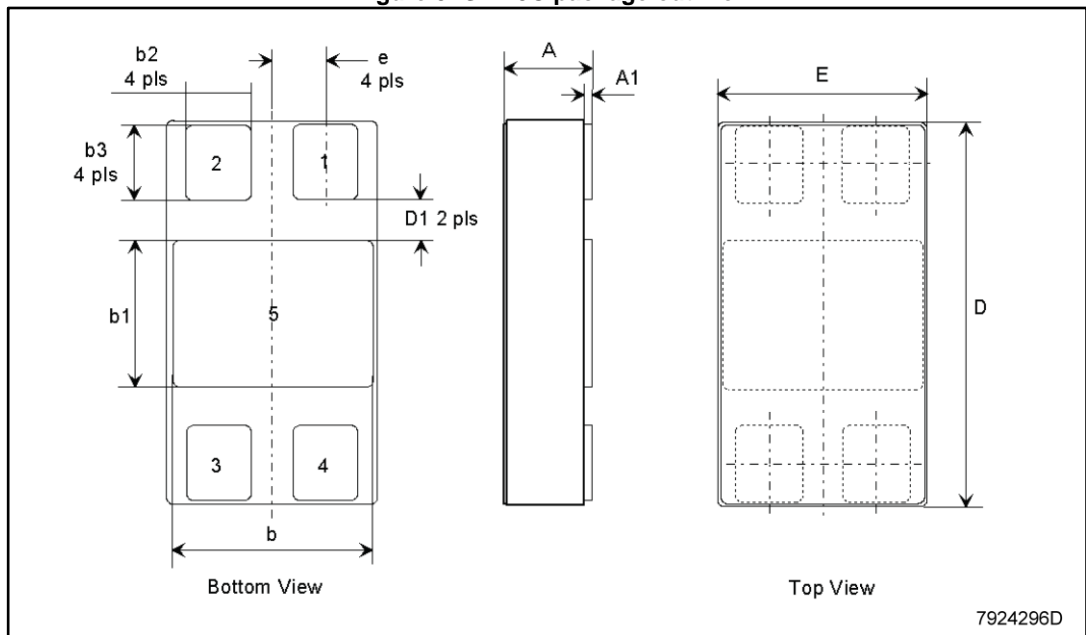

Table 6: Flat-16 (MIL-STD-1835) mechanical data

Dim.	mm		
	Min.	Typ.	Max.
A	2.42		2.88
b	0.38		0.48
c	0.10		0.18
D	9.71		10.11
E	6.71		7.11
E2	3.30	3.45	3.60
E3	0.76		
e		1.27	
L	6.35		7.36
Q	0.66		1.14
S1	0.13		

8.3 SMD5C package information

Figure 5: SMD5C package outline



7924296D

Table 7: SMD5C mechanical data

Dim.	mm		
	Min.	Typ.	Max.
A	2.99	3.15	3.30
A1	0.25	0.38	0.51
b	7.13	7.26	7.39
b1	4.95	5.08	5.21
b2	2.28	2.41	2.54
b3	2.92	3.05	3.18
D	13.71	13.84	13.97
D1	0.76		
E	7.39	7.52	7.65
e		1.91	

8.5 Packing information

RHFL7913A adjustable is available in high thermal dissipation 16 pin hermetic FLAT package, which bottom flange is metallized to allow direct soldering to heat sink (efficient thermal conductivity). It is also available in SMD5C hermetic ceramic package.

9 Order code

Table 8: Order code

Die	FLAT-16	SMD5C	Terminal finish	Quality level
	RHFL7913KPA1		GOLD	EM1
	RHFL7913KPA2		GOLD	EM2 = EM1 + 48hours BI
	RHFL7913KPA-01V		GOLD	QML-V
	RHFL7913KPA-02V		SOLDER	QML-V
		RHFL7913SCA1	GOLD	EM1
		RHFL7913SCA2	GOLD	EM2 = EM1 + 48hours BI
		RHFL7913SCA-03V	GOLD	QML-V
L7913ADIE2S				EM1 die
L7913ADIE2V				QML-V



EM1: Engineering parts, full temperature range, flight packages, no burn-in

EM2: Same as above but with burn-in, used in Satellite EQMs

Table 9: Part number - SMD equivalent

ST part number	SMD part number
RHFL7913KPA-01V	5962F0253201VXC
RHFL7913KPA-02V	5962F0253201VXA
RHFL7913SCA-03V	5962F0253202VYC
L7913ADIE2V	5962F0253201V9A

Table 10: Environmental characteristics

Parameter	Conditions	Value	Unit
Output voltage thermal drift	-55 °C to +125 °C	40	ppm/°C
Output voltage radiation drift	From 0 krad to 300 krad at 0.55 rad/sec	8	ppm/krad
Output voltage radiation drift	From 0 krad to 300 krad, MIL1019.5	6	ppm/krad

10 Revision history

Table 11: Document revision history

Date	Revision	Changes
16-May-2006	1	First release.
22-Aug-2006	2	The pin description for SMD5C on table 1 updated.
19-Dec-2007	3	Modified: Table 8: "Order codes" .
26-Aug-2008	4	Modified: not found, Table 1: "Pin description" , the V_I value Table 4: "Recommended operating conditions" , Table 5: "Electrical characteristics" and Section 6: "Application information" .
22-Sep-2008	5	Modified: Table 1: "Pin description" for SMD5C.
07-Feb-2011	6	Added: note Table 1: "Pin description" .
07-Dec-2011	7	Removed the note under Table 1: "Pin description" and added footnotes 1 and 2.
02-Mar-2015	8	Updated Table 8: "Order codes" and Section 8: "Package information" . Minor text changes.

IMPORTANT NOTICE – PLEASE READ CAREFULLY

STMicroelectronics NV and its subsidiaries ("ST") reserve the right to make changes, corrections, enhancements, modifications, and improvements to ST products and/or to this document at any time without notice. Purchasers should obtain the latest relevant information on ST products before placing orders. ST products are sold pursuant to ST's terms and conditions of sale in place at the time of order acknowledgement.

Purchasers are solely responsible for the choice, selection, and use of ST products and ST assumes no liability for application assistance or the design of Purchasers' products.

No license, express or implied, to any intellectual property right is granted by ST herein.

Resale of ST products with provisions different from the information set forth herein shall void any warranty granted by ST for such product.

ST and the ST logo are trademarks of ST. All other product or service names are the property of their respective owners.

Information in this document supersedes and replaces information previously supplied in any prior versions of this document.

© 2015 STMicroelectronics – All rights reserved