

# TCM Serie

## Common Mode Choke

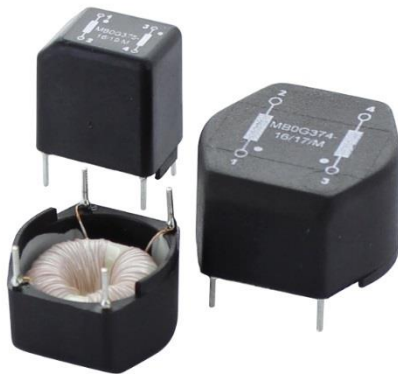

### BENEFITS

Designed and qualified for aerospace  
 Through Hole package -  
 RMS current range from 0.3 A to 4A  
 Dielectric withstanding strength 1500V AC  
 Materials meet UL94-V0 rating  
 Operating temperature range : -55°C - +125°C  
 High mechanical resistance

### APPLICATION



TMC range	
TCM14 xxx H	0.3A/12mH -> 2A/1.1mH
TCM17 xxx H	0.4A/39mH -> 4A/0.7mH
TCM22 xxx H	0.3A/47mH → 4A/1.5mH
TCM28 xxx H	0.6A/47mH → 2.5A/3.3mH
TCM18 xxx V	0.3A/12mH → 2A/1.1mH
TCM19 xxx V	0.4A/39mH → 4A/0.7mH
TCM23 xxx V	0.3A/47mH → 4A/1.5mH

TCM14			
	Nominal Current (A)	Inductance value per winding (mH)	Rdc per winding Typ (mΩ)
TCM14 12M H	0,3	12	1275
TCM14 4M4 H	0,6	4,4	385
TCM14 3M0 H	1	3	205
TCM14 1M6 H	1,5	1,6	100
TCM14 1M1 H	2	1,1	70

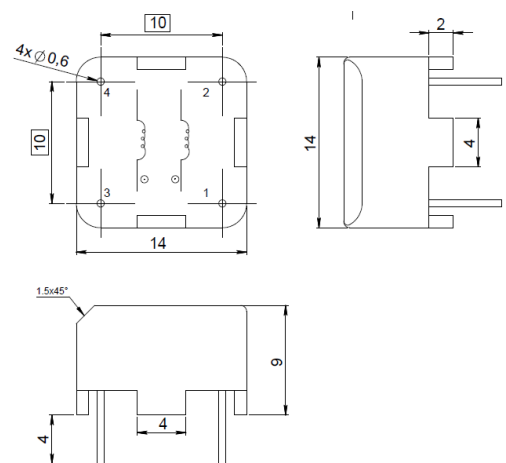

# TCM Serie

## Common Mode Choke

### TCM17

	Nominal Current (A)	Inductance value per winding (mH)	Rdc per winding Typ (mΩ)
TCM17 39M H	0,4	39	1460
TCM17 27M H	0,5	27	1250
TCM17 15M H	0,6	15	465
TCM17 10M H	0,8	10	370
TCM17 6M8 H	1,2	6,8	245
TCM17 3M3 H	1,5	3,3	135
TCM17 1M8 H	2	1,8	75
TCM17 M70 H	4	0,7	27

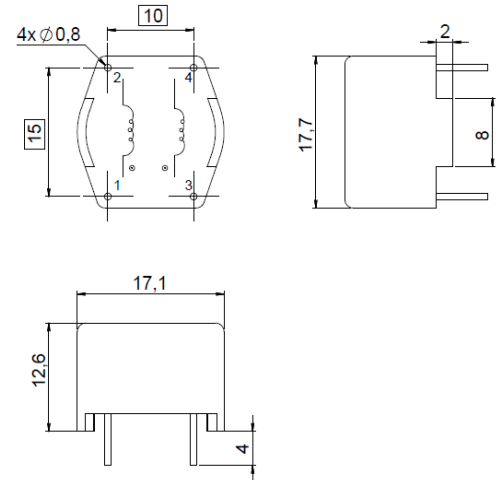

### TCM22

	Nominal Current (A)	Inductance value per winding (mH)	Rdc per winding Typ (mΩ)
TCM22 47M H	0.3	47	1750
TCM22 39M H	0.5	39	810
TCM22 27M H	0.8	27	500
TCM22 15M H	1	15	375
TCM22 10M H	1.2	10	200
TCM22 6M8 H	1.5	6.8	130
TCM22 4M2 H	2	4.2	102
TCM22 3M3 H	2.5	3.3	72
TCM22 2M0 H	3	2	55
TCM22 1M5 H	4	1.5	35

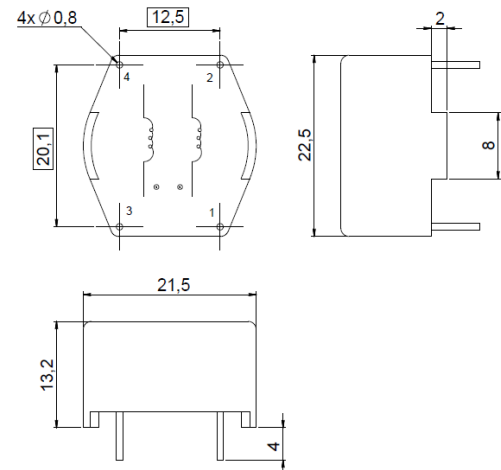

### TCM28

	Nominal Current (A)	Inductance value per winding (mH)	Rdc per winding Typ (mΩ)
TCM28 47M H	0.6	47	1180
TCM28 39M H	0.8	39	1000
TCM28 18M H	1	18	610
TCM28 10M H	1.5	10	220
TCM28 6M8 H	2	6.8	147
TCM28 5M6 H	2.5	5.6	105
TCM28 4M5 H	3	4.5	80
TCM28 3M3 H	4	3.3	45

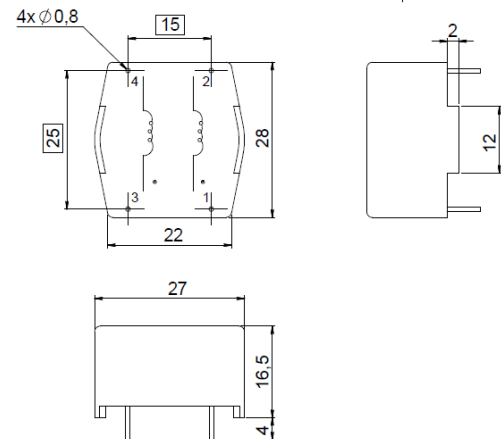

# TCM Serie

## Common Mode Choke

### TMC18

	Nominal Current (A)	Inductance value per winding (mH)	Rdc per winding Typ (mΩ)
<b>TCM18 12M V</b>	0.3	12	1275
<b>TCM18 4M4 V</b>	0.6	4.4	385
<b>TCM18 3M0 V</b>	1	3	205
<b>TCM18 1M6 V</b>	1.5	1.6	100
<b>TCM18 1M1 V</b>	2	1.1	70

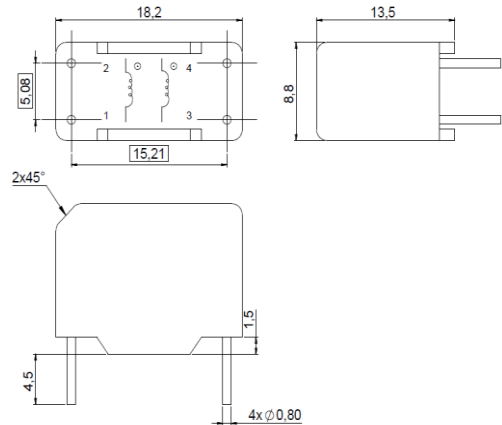

### TMC19

	Nominal Current (A)	Inductance value per winding (mH)	Rdc per winding Typ (mΩ)
<b>TCM19 39M V</b>	0.4	39	1460
<b>TCM19 27M V</b>	0.5	27	1250
<b>TCM19 15M V</b>	0.6	15	465
<b>TCM19 10M V</b>	0.8	10	370
<b>TCM19 6M8 V</b>	1.2	6.8	245
<b>TCM19 3M3 V</b>	1.5	3.3	135
<b>TCM19 1M8 V</b>	2	1.8	75
<b>TCM19 0M7 V</b>	4	0.7	27

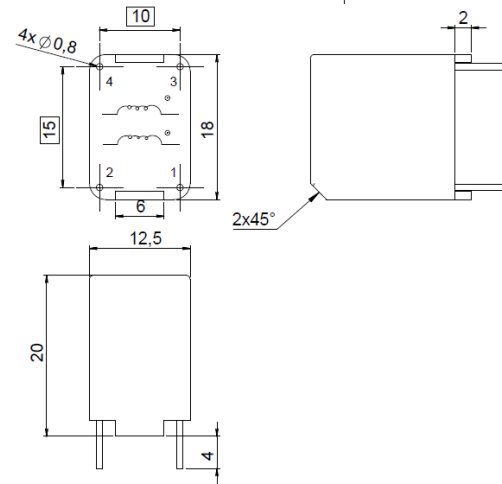

### TMC23

	Nominal Current (A)	Inductance value per winding (mH)	Rdc per winding Typ (mΩ)
<b>TCM23 47M V</b>	0.3	47	1750
<b>TCM23 39M V</b>	0.5	39	810
<b>TCM23 27M V</b>	0.8	27	500
<b>TCM23 15M V</b>	1	15	375
<b>TCM23 10M V</b>	1.2	10	200
<b>TCM23 6M8 V</b>	1.5	6.8	130
<b>TCM23 4M2 V</b>	2	4.2	102
<b>TCM23 3M3 V</b>	2.5	3.3	72
<b>TCM23 2M0 V</b>	3	2	55
<b>TCM23 1M5 V</b>	4	1.5	35

